

BME690

8x Shuttle board 3.0 flyer

1 General description

The Bosch Sensortec BME690 8xshuttle board 3.0 is a PCB with the gas, pressure, temperature and humidity sensor BME690 mounted on it. In combination with the application board 3.x, the shuttle board can be used to evaluate the signal outputs provided by the sensor itself as well as the additional outputs generated by the BSEC library for BME690. The shuttle board allows easy access to the sensor pins via a simple socket and can be directly plugged into the Bosch Sensortec application board 3.x.

Typically, the BME690 shuttle board with eight sensors can be used to collect, train and test the custom use case application using the BME AI Studio ecosystem.

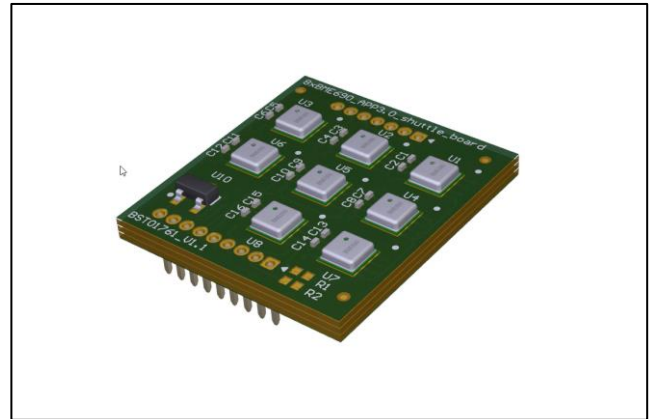

BME690 8xShuttle board 3.0

Note: Product photo may differ from real product's appearance

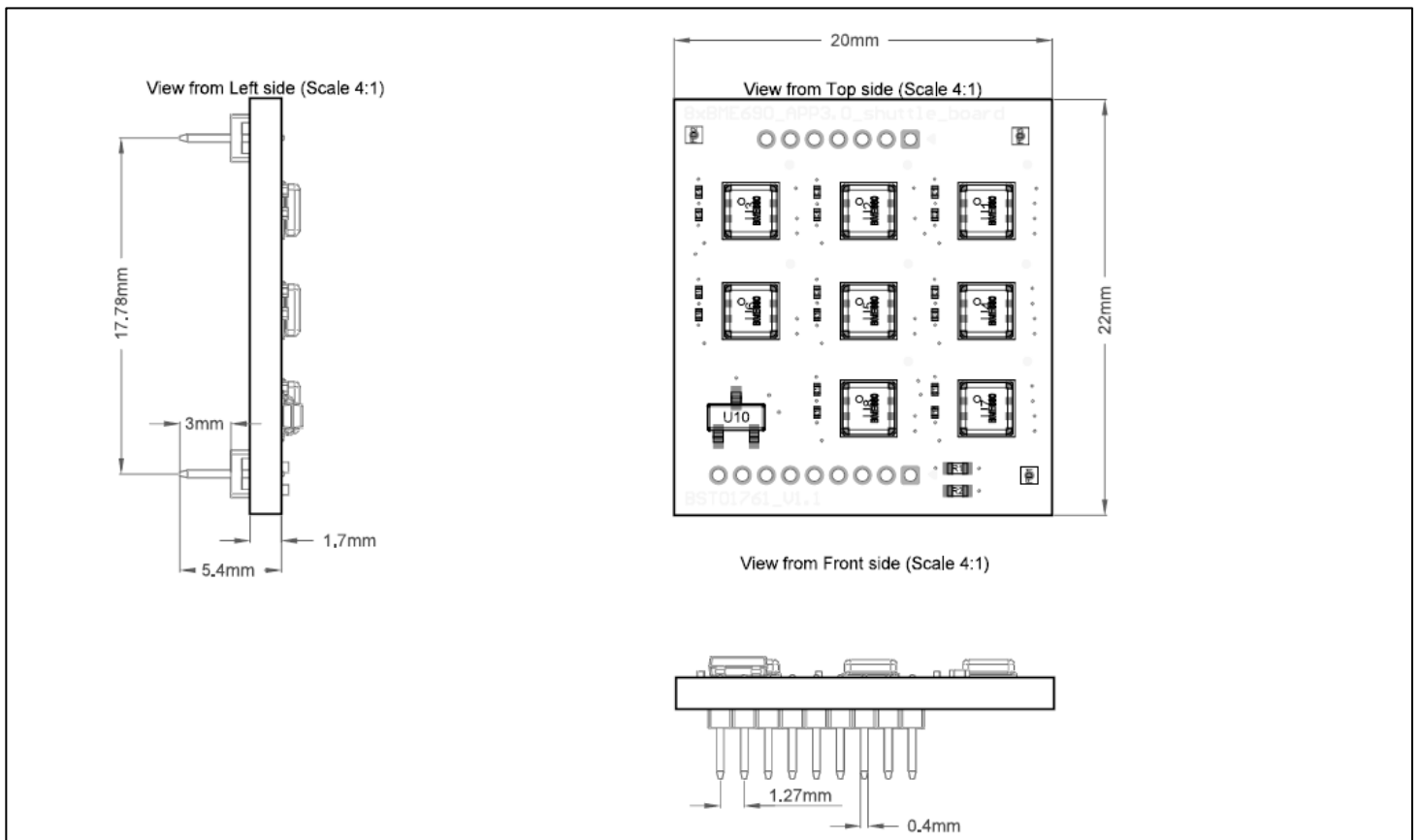

Shuttle board outline dimension

All dimensions in mm

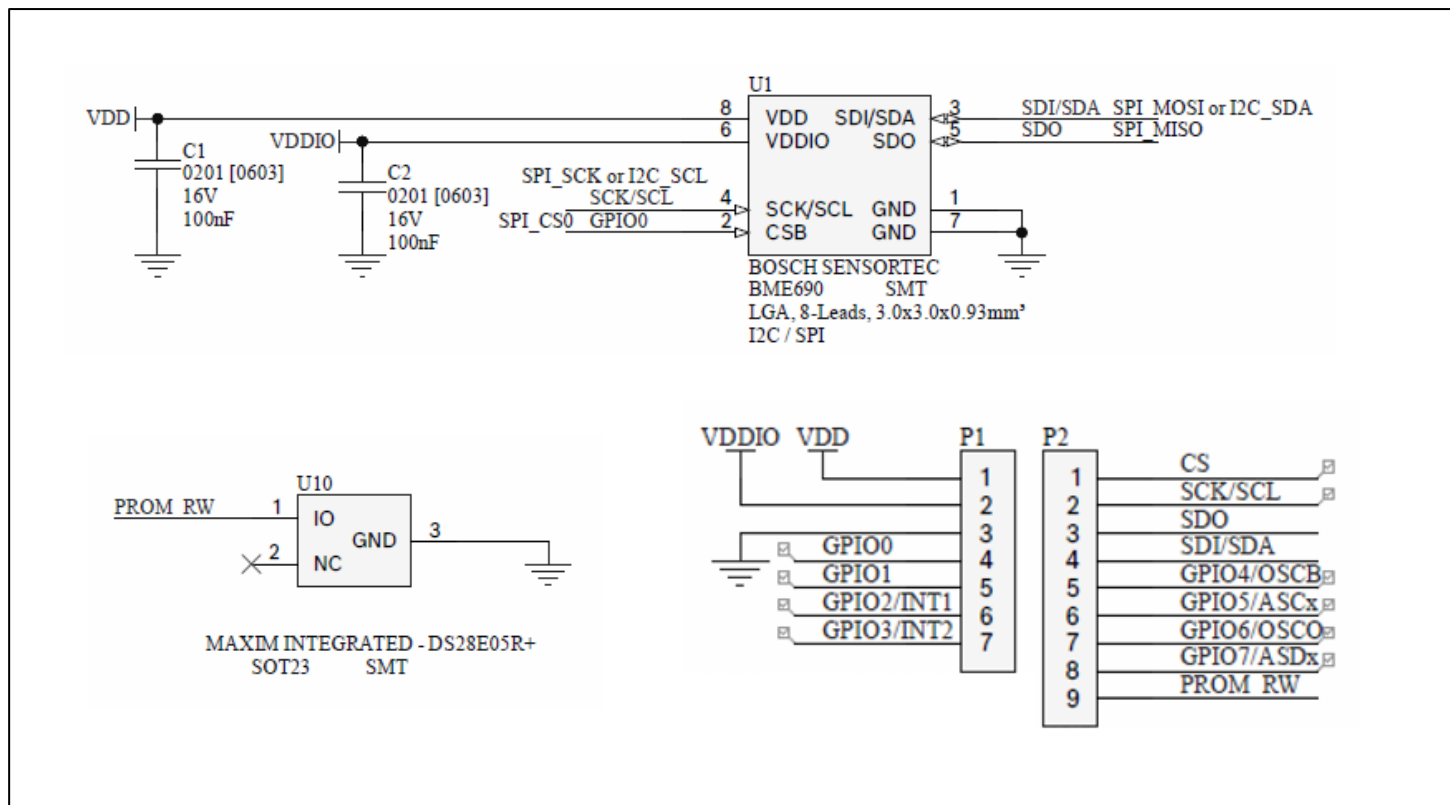

Electrical layout

2 Designator P1 shuttle board connector

Pin	Pin name	Description
1	VDD	Power supply
2	VDDIO	Power supply
3	GND	Ground
4	GPIO0	Connected to U1 pin 2
5	GPIO1	Connected to U2 pin 2
6	GPIO2/INT1	Connected to U3 pin 2
7	GPIO3/INT2	Connected to U4 pin 2

Shuttle board identification:

- Sales Part Number: 0440 SB9 048
- Shuttle board ID: BST01761 V1.1
- Chip ID: 0x61
- Shuttle ID: 0x93

3 Designator P2 shuttle board connector

Pin	Pin name	Description
1	CS	Chip selection pin of SPI bus
2	SCK/SCL	Clock pin of both SPI and I2C bus
3	SDO	Master-input-slave-output data pin of SPI bus
4	SDI/SDA	Master-output-slave-input data pin of SPI bus / data pin of I2C bus
5	GPIO4	Connected to U5 pin 2
6	GPIO5	Connected to U6 pin 2
7	GPIO6	Connected to U7 pin 2
8	GPIO7	Connected to U8 pin 2
9	PROM_RW	Connect to EEPROM

Headquarters Bosch Sensortec GmbH

Gerhard-Kindler-Strasse 9
72770 Reutlingen · Germany
Telephone +49 7121 3535 900
Fax +49 7121 3535 909

www.bosch-sensortec.com